

# Collaborative Technology Alliance (CTA)

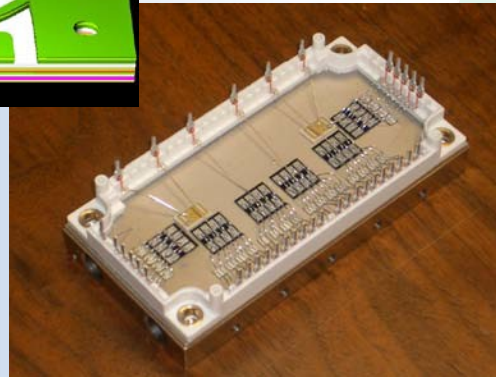

## Power & Energy (P&E)

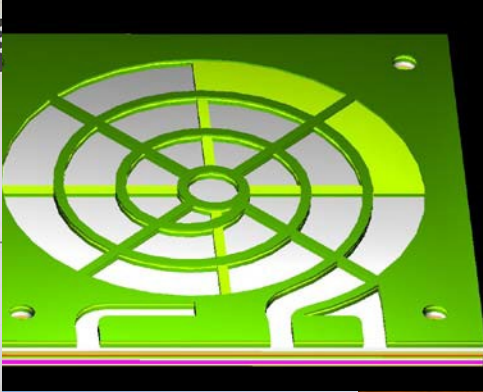
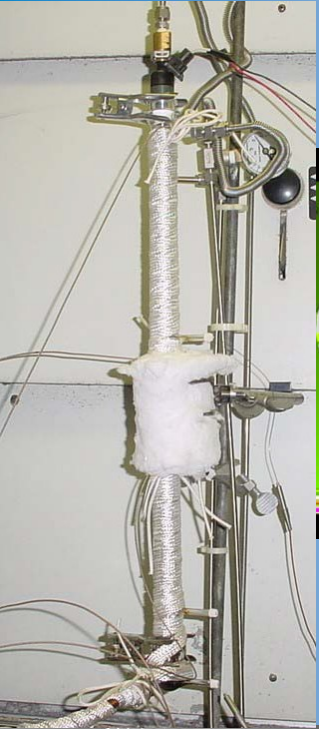
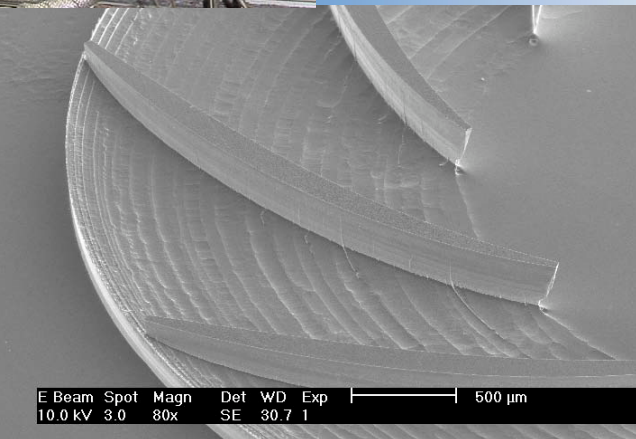

*Mr. John Hopkins*  
*ARL Collaborative Alliance Manager*

**Honeywell**

*Dr. Mukund Acharya*  
*Consortium Manager,*  
*Honeywell Engines, Systems & Services*



# Power and Energy Collaborative Technology Alliance



## Consortium Partners

- Honeywell (lead)
- MIT
- Clark Atlanta
- Georgia Tech
- U of Maryland
- Motorola Labs
- U of New Mexico
- Case Western Reserve U
- DuPont Fuel Cells
- NuVant Systems
- U of Puerto Rico
- Penn State Univ
- Delphi Automotive
- Tufts Univ
- U of Minnesota
- U of Pennsylvania
- U of Texas – Austin
- SAIC
- United Defense LP
- Rensselaer Polytechnic
- Rockwell Scientific

## Objectives

Research and develop technologies that enable lightweight, compact power sources and highly power dense components that will significantly reduce the logistics burden, while increasing the survivability and lethality of the soldiers and systems of the highly mobile mounted and dismounted forces of the Future Army.

**Supporting Transformation Goals**

## Technical Areas

- Portable, Compact Power Sources (Non-electrochemical)
- Fuel Cells and Fuel Reformation
- Hybrid Electric Propulsion and Power

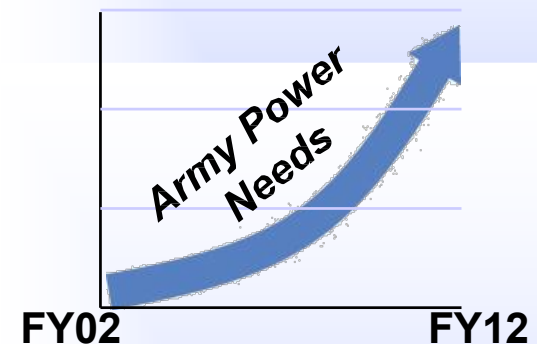



# Power and Energy Collaborative Technology Alliance

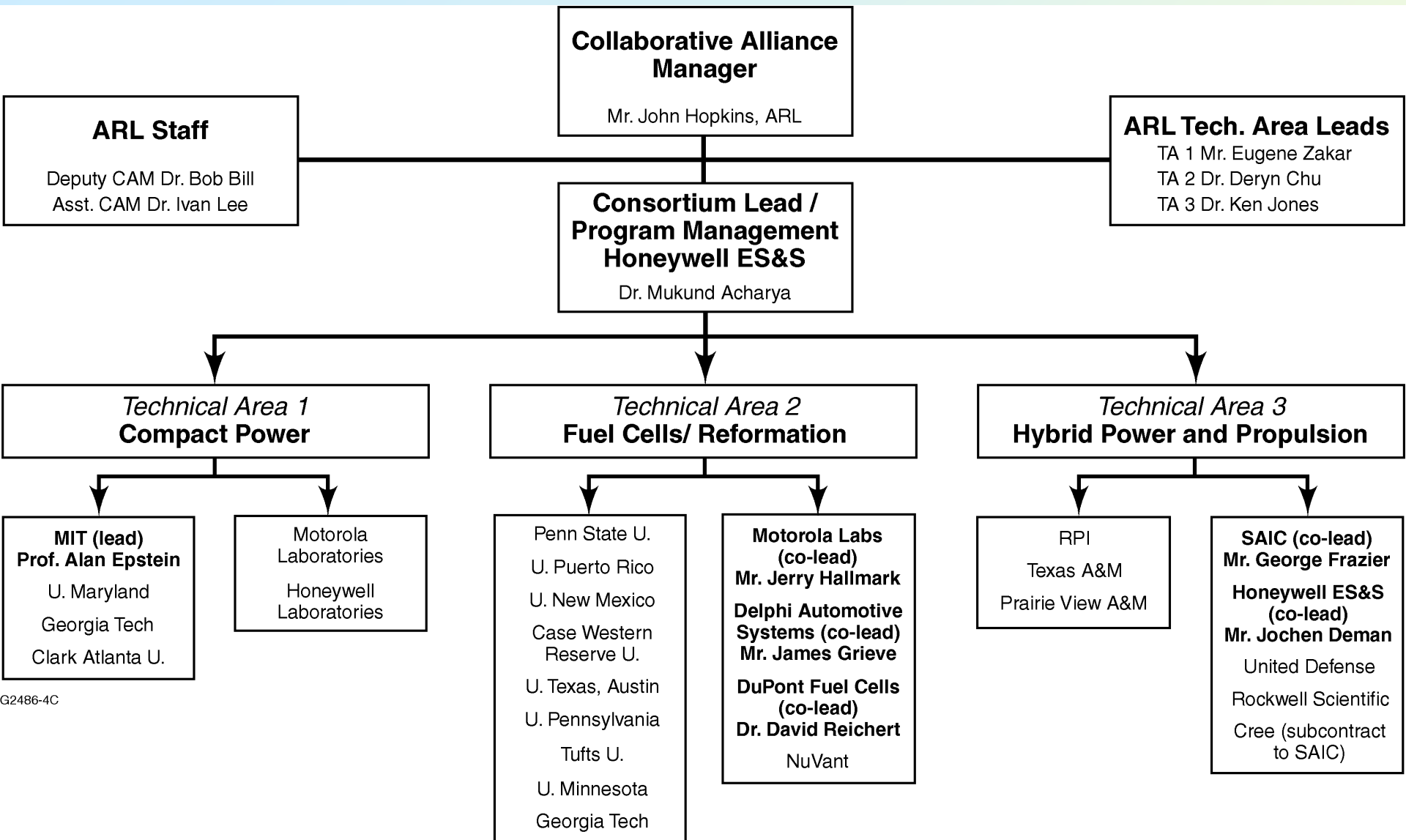



# DoD and Commercial Industry Requirements

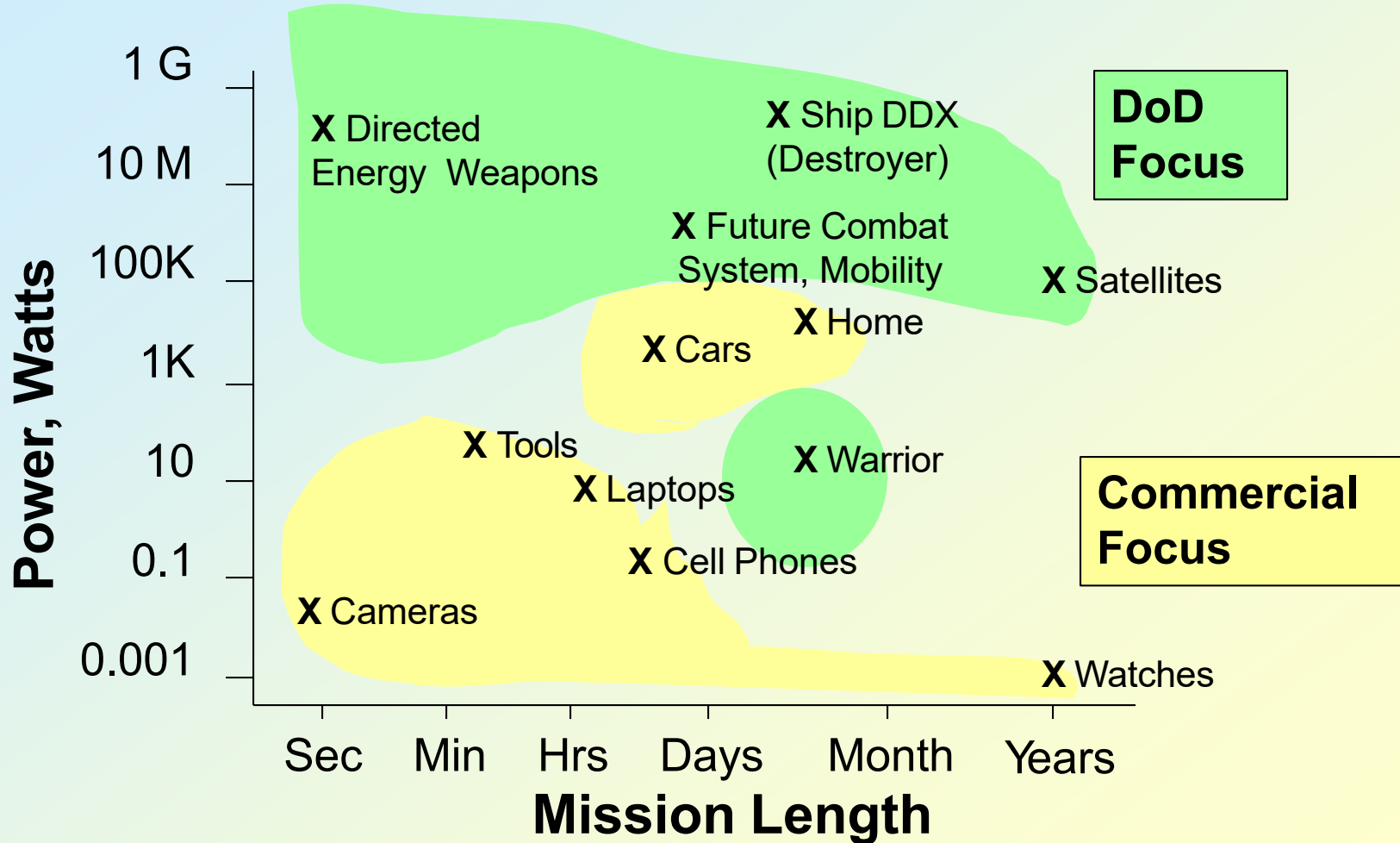



# Power and Energy Taxonomy



## Operational Regimes

**Unit of Action**

Responsive Deployable  
 Agile and Versatile  
 Lethal Survivable  
 Sustainable

## System of Systems Platforms

Ground Manned & Unmanned Mobile & Non-Mobile

Airborne Manned & Unmanned Munitions

Soldier Future Force Warrior, Land Warrior

Unattended Ground Sensors & Munitions

## Platform Applications

Hybrid Electric/ Propulsion	Environment Management	Dynamic Armor	EM, ETC, DE Weapons	Active Protection	C4 ISR	Signature Management	UGS, Munitions, Other
-----------------------------	------------------------	---------------	---------------------	-------------------	--------	----------------------	-----------------------

## Technologies

Switches : Capacitors : Batteries : Power Converters : Fuel Cells : Fuel Reformation  
 Thermal Management : Power Control:  
 Power Generation



# Hybrid-Electric Combat Vehicle



## *Future Combat Systems*

- Common power source for propulsion, EM/ETC gun, armor, and auxiliary - ability to shift power away from propulsion
- Enables improved stealth, near silent watch, and extended vehicle range
- > 50% increase in transient power at wheels - enhances mobility
- Increased flexibility of vehicle system integration yields up to 10% increase in useable internal volume

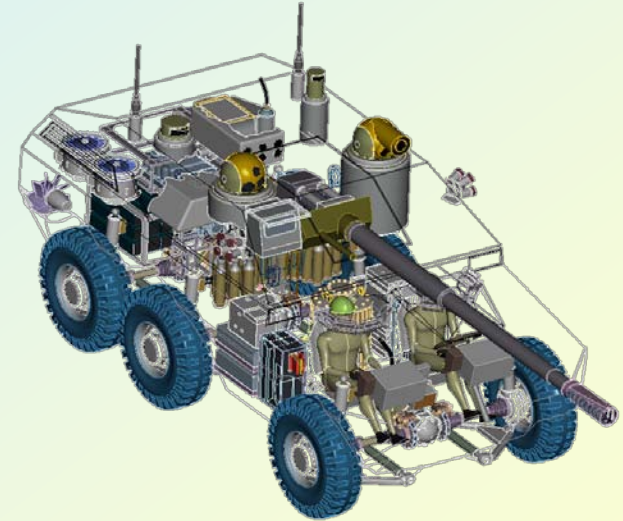

### • Required Technology

- **Power Generation**: 2X more efficient and 2X more power dense generation
- **Energy Storage**: Energy storage at 50 kW-hr (10's MJ) and pulsed power capacitors up to 5 MW
- **Power Control and Distribution**: High power switches, control and distribution

### Payoff in FY2010:

- Fuel savings up to 50%
- Reduction in armor and ammunition weight hence transport costs
- New capability for EM/ETC gun and dynamic armor



# Cross-Service Critical Applications

## Warrior Power



Hybrid JP-8 fueled charger/rechargeable battery system capable of:

- eliminating non-rechargeable batteries
- weighing 1/3 less than non-rechargeables
- extending mission time per system up to 6X

Rechargeable batteries charged 2-3X faster

Power Management design tools reduce power consumption 2 to 5 times.



### Required Technology:

**Energy Storage**: Battery reactants with 3X increase in energy storage and 6X increase in power density, **Novel liquid electrolyte reserve batteries, TRL 6, FY07.**

**Power Control**: Efficient chargers for two hour charge time and techniques to reduce power consumption by 50% in Soldier Systems

**Power Generation**: Logistic fuel reformation, **Direct Methanol Fuel Cells, 750Wh/kg, 150oC, TRL6, FY06**

**Return on Investment  
FY08 (1 Battalion, 96 Hour  
Mission):**

**4400 Disposable Batteries,  
\$500,000, 8800 pounds**

**VERSUS**

**200 Gallons JP-8, Rechargeable  
Batteries, \$400, 1600 pounds for  
fuel**

**DMFC Fuel Cell Demo FY06**



# P&E CTA Focused on Three Technical Areas

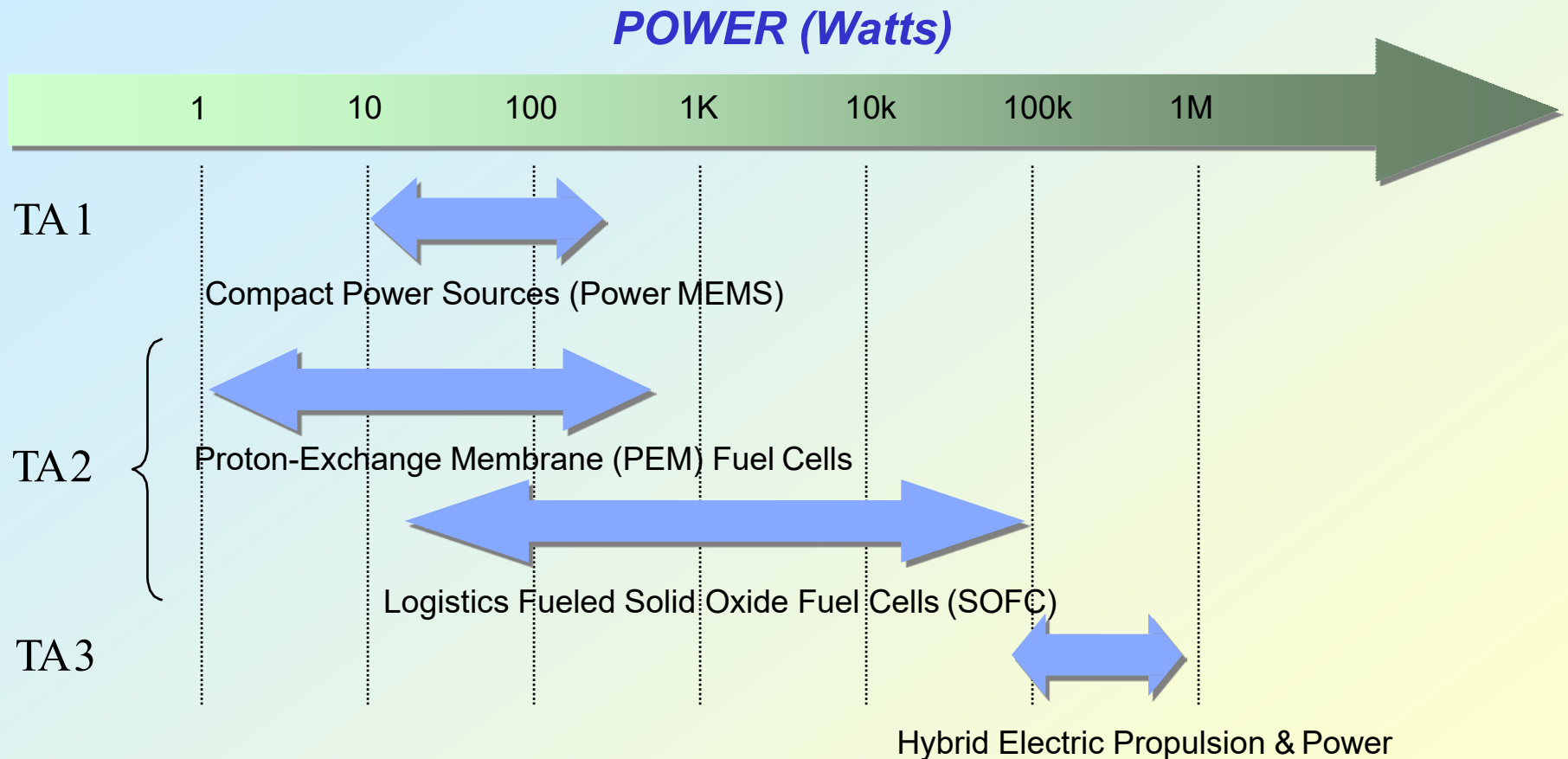

**Technical Area Power Levels Meet the Goals of Transformation for Soldier and Vehicular Loads**





# Portable Compact Power Sources



**Gas Turbine & Electrostatic Generator**

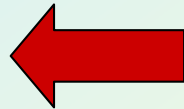
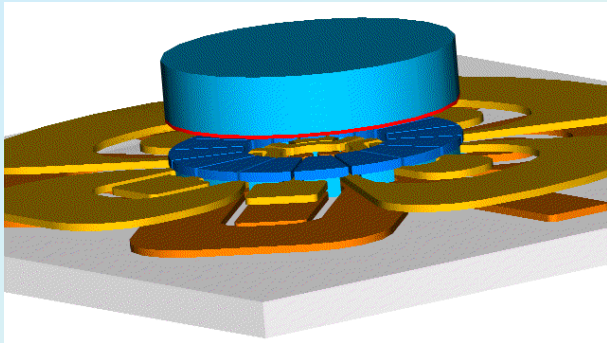
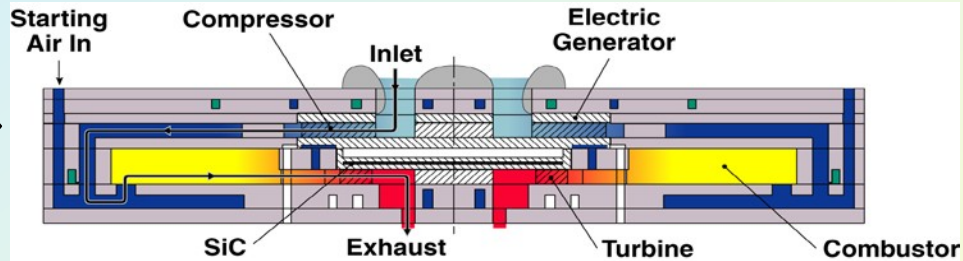
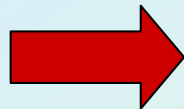

**Electromagnetic Generator**

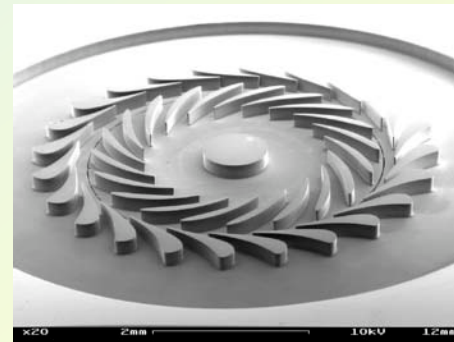

**Microfab Technology**

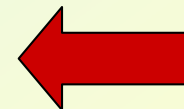
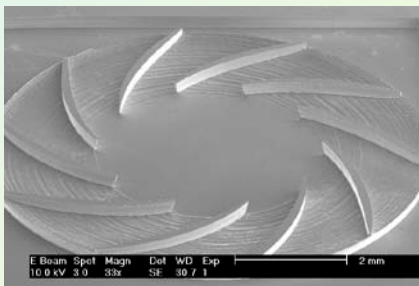
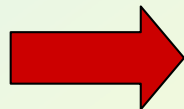

**Component Fabrication & MEMS Process Development**



# Portable Compact Power Sources

## MEMS GAS TURBINE ENGINE



### Technical Challenges:

- Improved yield from MEMS fabrication of highly complex devices
- Stable high speed rotation of silicon micro-rotors
- Silicon structure strength at high temperatures
- High performance levels from small-scale engine components

### Recent Accomplishments:

- Micro-turbocharger operated at high speed (up to 480,000 rpm)
- Micro-catalytic combustor demonstrated
- Magnetic generator device designed
- Startup model for the gas turbine engine developed



Compressor



Gas Phase Combustion



Catalytic Combustor

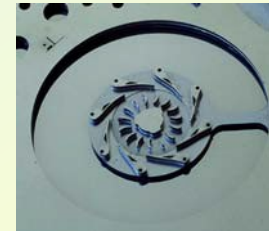

Turbine

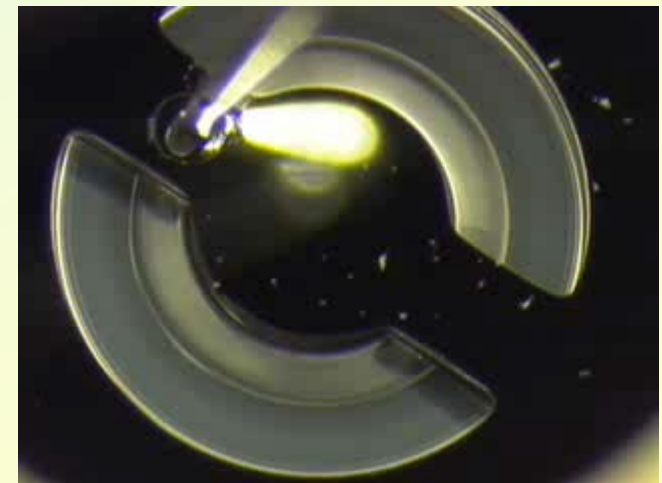



# Portable Compact Power Sources

## LAMINATED MAGNETIC GENERATOR STATOR

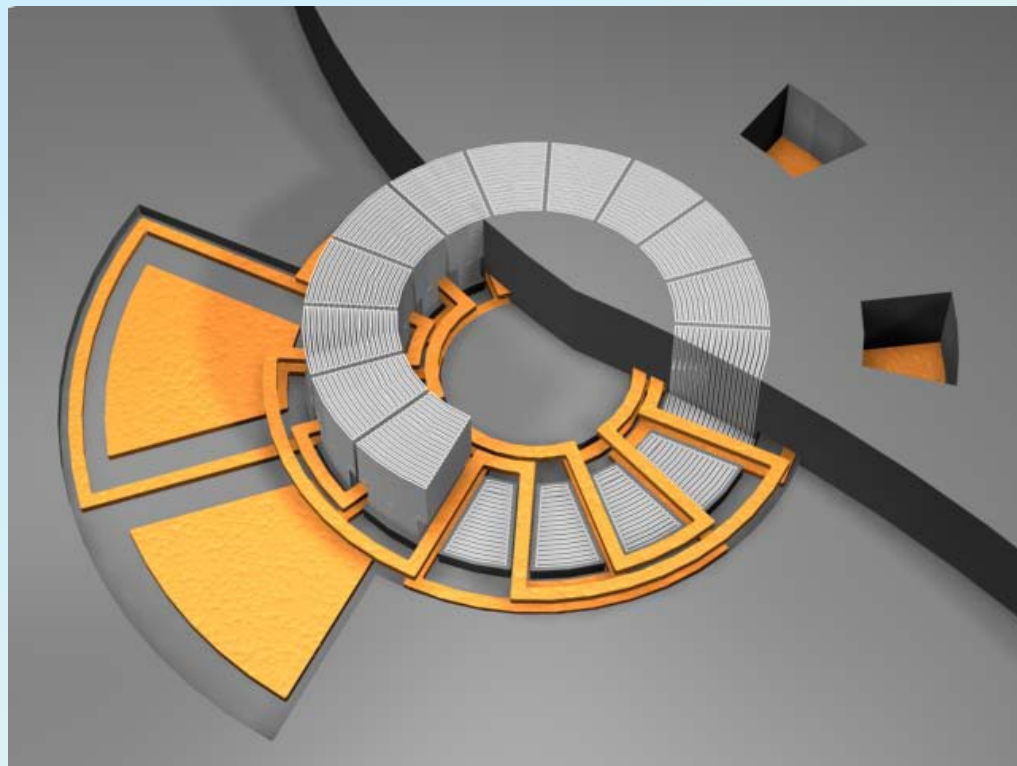

**Cutaway of a MEMS magnetic generator**

- Laminations reduce eddy current losses
- Laminated microstructures were beyond the SOA
- New fabrication processes developed & demonstrated

**Fabricated induction generator**

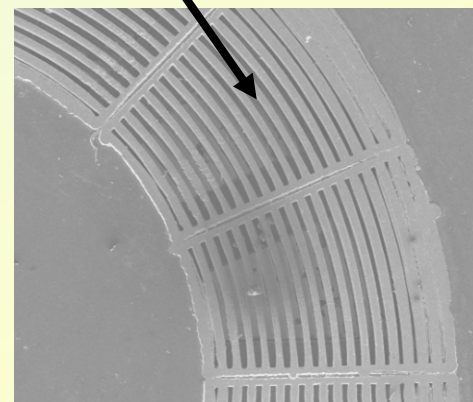
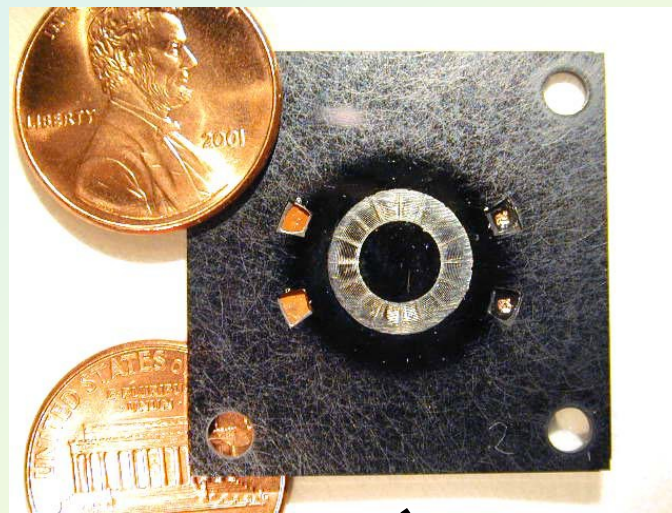

**Laminated Stator**



# Portable Compact Power Sources

## 3-D Profiles in Photoresist Film

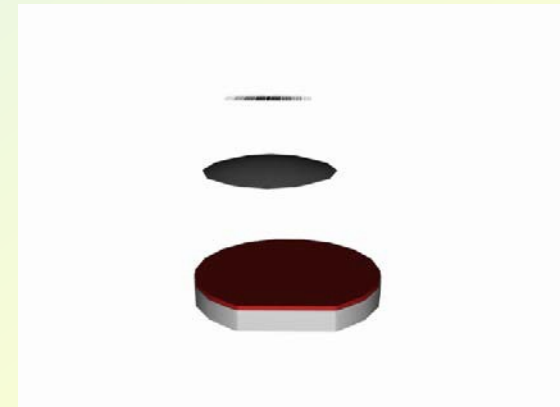
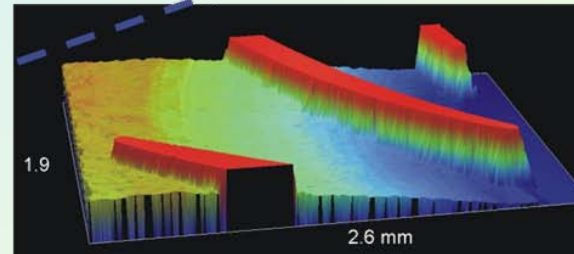
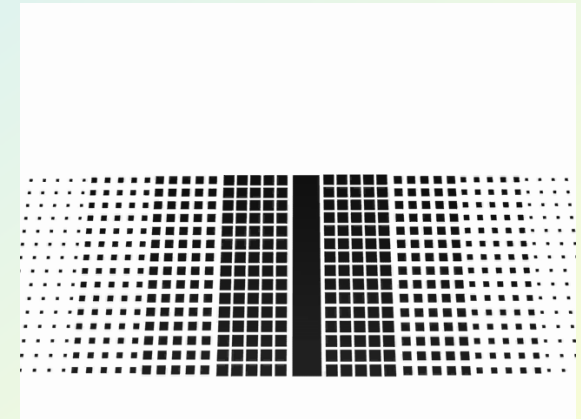
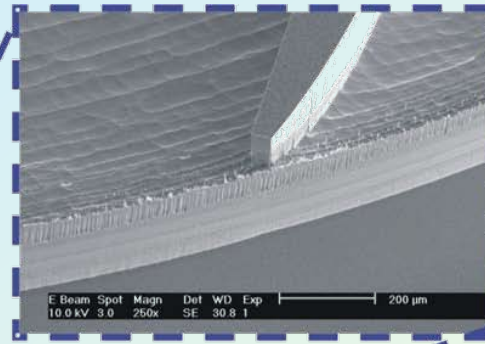
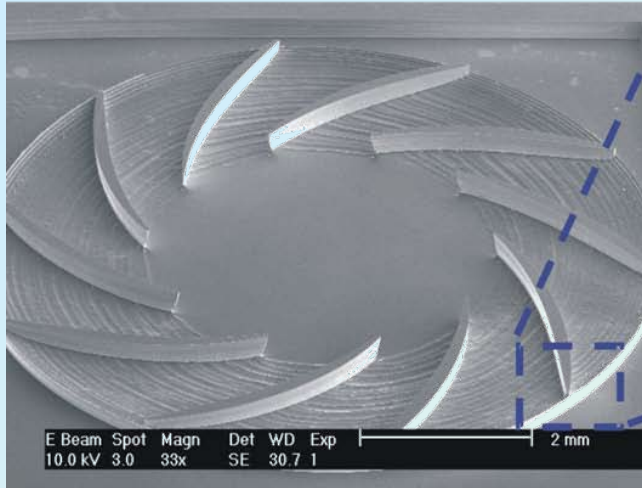

- **New micromachining processes**
  - Continuously variable height silicon structure demonstrated
  - Grey-scale lithography makes 3D structures possible
  - Gas turbines use extensive 3D geometries
  - Process expands gas-turbine design space, improving performance



# Fuel Cells and Fuel Reformulation

## SOFC and Logistics Fuel Reformulation

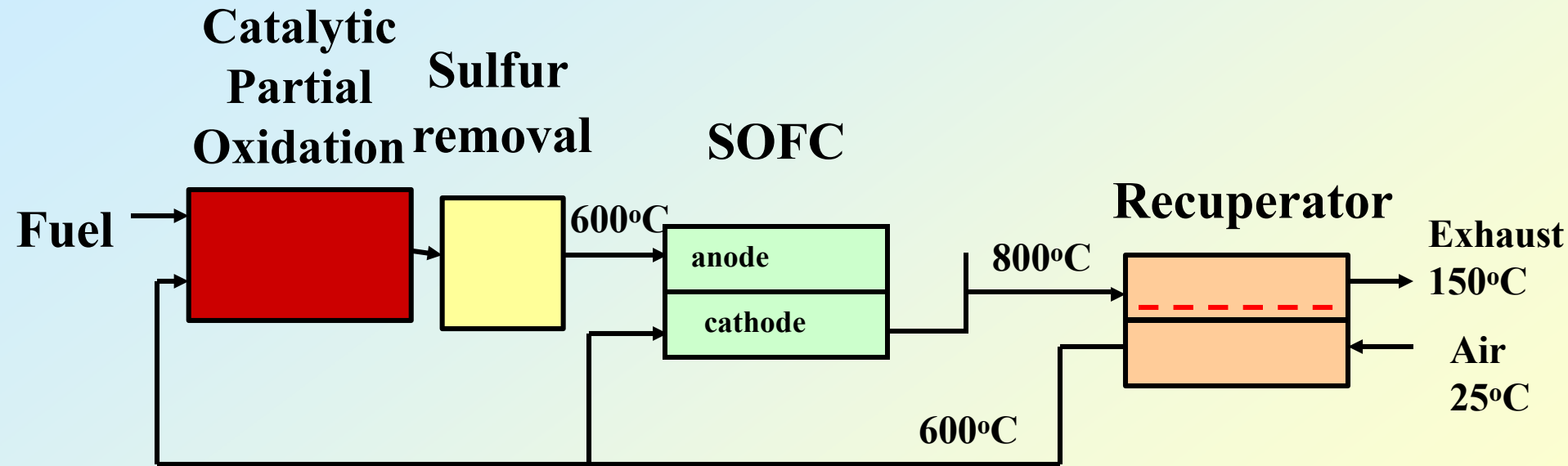



# Fuel Reforming: Advanced Catalysts



## Technical Challenges:

- Convert Logistic Fuels and components to Hydrogen rich gas streams for SOFCs
- Develop advanced catalysts, supports and materials for catalytic partial oxidation (CPOX)
- Obtain operating parameters and that yield high conversion
- Model reactions

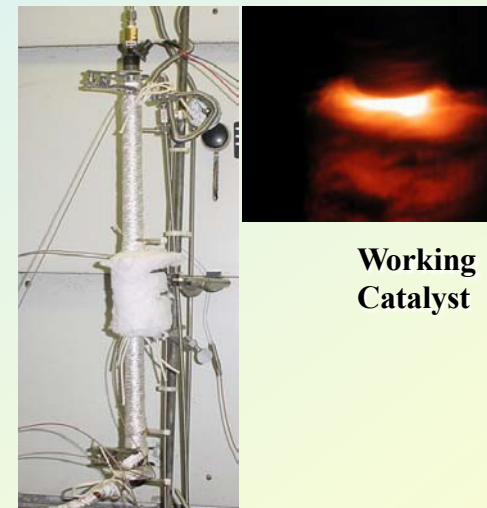
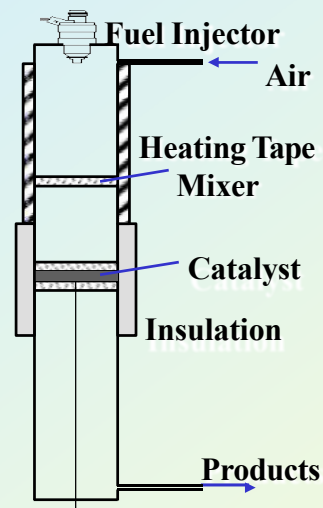

Working Catalyst



## Recent Accomplishments:

- Reforming of decane, hexadecane and low-sulphur diesel fuel
- Demonstrated fast lightoff of octane, iso octane, decane and hexadecane
- Determined limits of safe operation without flames or explosions
- Quantification and modeling of carbon formation



# SOFC Stack and System Level Assessment

## Technical Challenges:

- Trade-offs in power density, system efficiency and fuel tolerance drive towards higher stack temperature. Metallic interconnects are a weak link in operating above 800 C.
- Reforming, Desulfurization and Stack processes interact and must be configured into a system. Assessment of the CTA and other technical progress is needed to estimate system performance and to optimize the system for Army needs.

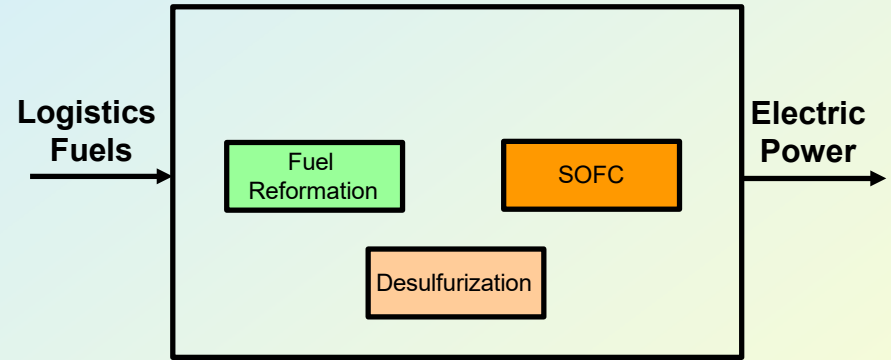

## Recent Accomplishments:

- Development of screening tests for interconnect alloy evaluation.
- Development of Hysys models for system.
- Coupled proprietary version of stack electrochemical model to system model.





# Fuel Cells and Fuel Reformation

## Reformed Methanol Fuel Cells



**RHFC systems,  
peripherals, integration**

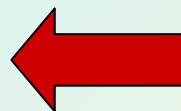
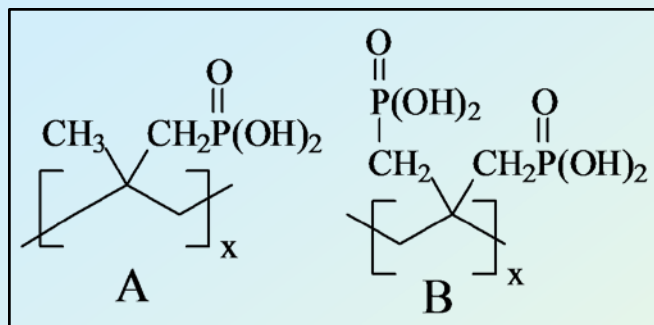

**Polyphosphonic Dopants  
for Membranes**

**Reformer-ceramic materials  
synthesis and processing**

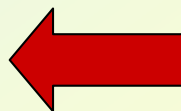
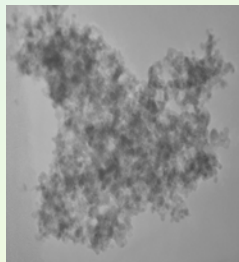
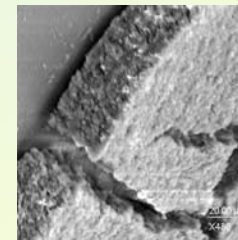
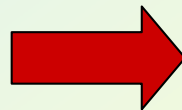

**High Temperature Membranes**





# Reformed Hydrogen Fuel Cell System



## Technical Challenges:

- Identify materials that are chemically compatible for long term operation of elevated temperature fuel cell stack
- Develop low-pressure-drop 20W stack with optimal characteristics
- Develop 20W fuel processor for demonstration of principle

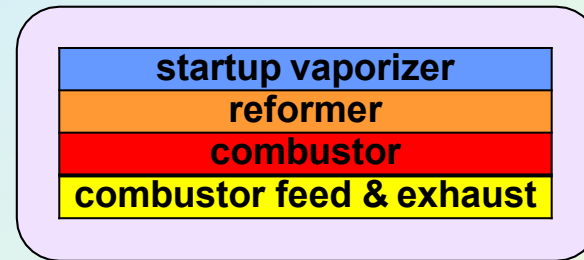

**Outer dimensions**  
L = 49 mm  
W = 49 mm  
H = 5 mm

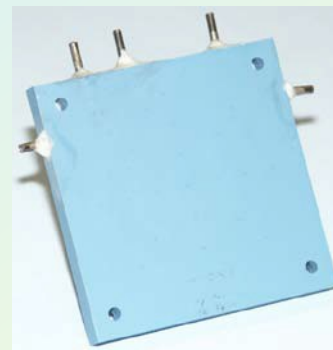

## Recent Accomplishments:

- Completed CFD model of the Gen 1 integrated fuel processor
- Completed design and construction and currently testing Gen 3.1 fuel processor (sized for 5W system)
- Demonstrated 2W proof of principle system running for >90hrs on mini-pumps with rudimentary control scheme

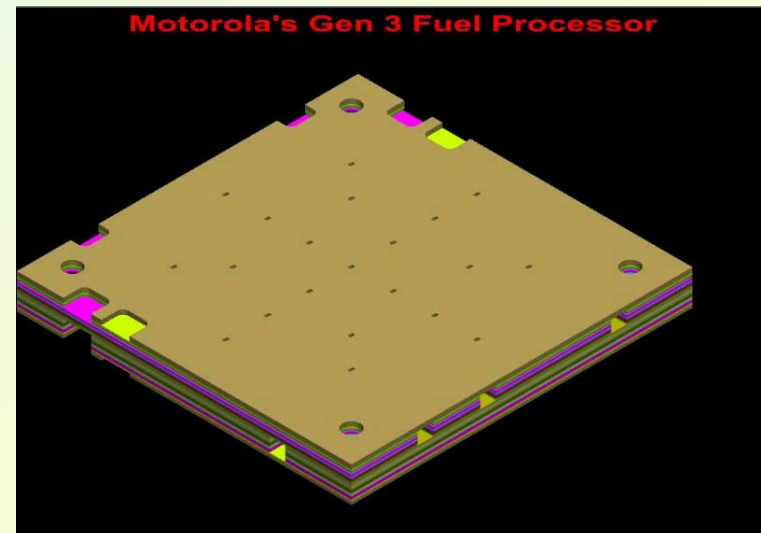



# Reforming Catalyst in Porous Ceramic Support



## Technical Challenges:

- Develop methods of wall coating of preformulated, industrial catalysts.
- Catalyst for Microchannel reformers must provide low pressure drop and high activity
- Demonstrate performance of wall coated reactor for hydrogen production
- Catalyst coating should be adherent and stable for long term use

## Recent Accomplishments:

- Analysis of Heat and Mass Transfer Limitations in Packed Bed and Wall Coated Reformers
- 25  $\mu\text{m}$  wall coat of catalyst demonstrated within microchannels
- Reactivity of wall coated catalyst exceeds that of packed bed

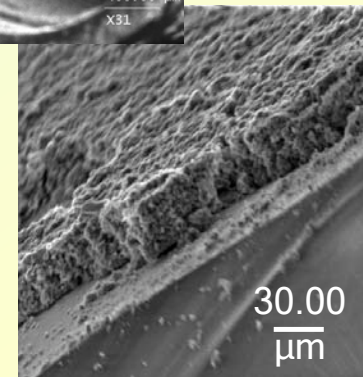
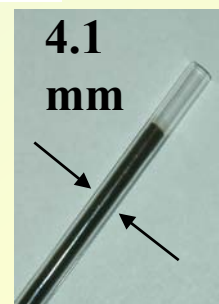
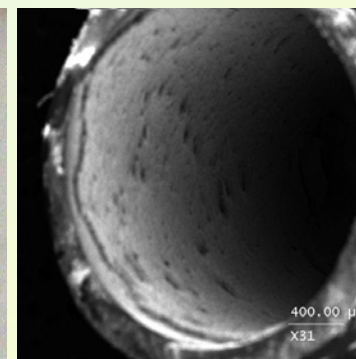
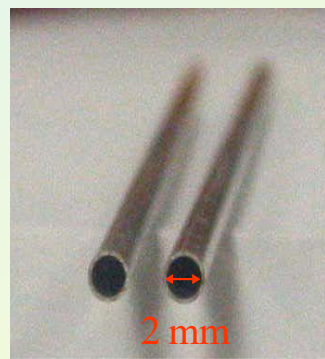
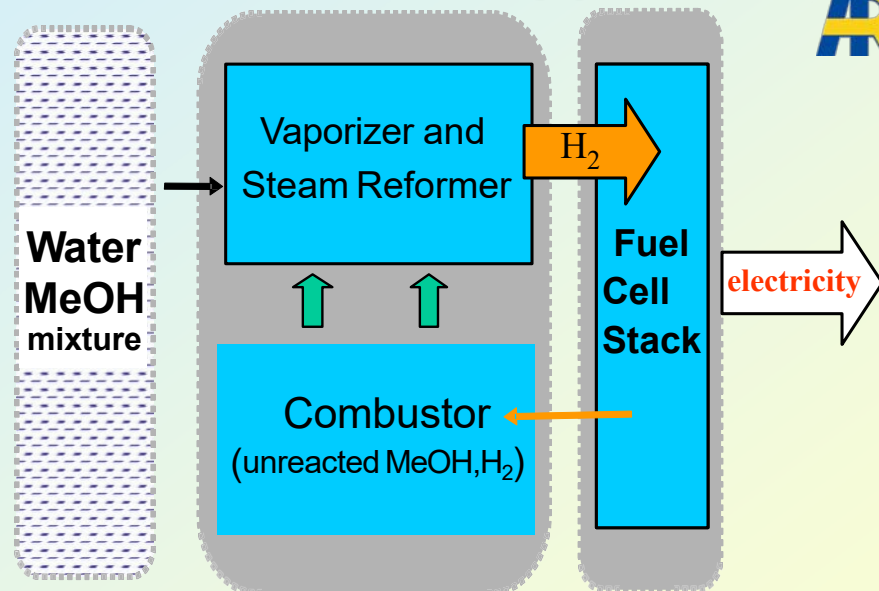

Catalyst coating, 25  $\mu\text{m}$ .



# Fuel Cells and Fuel Reformation

## Direct Methanol Fuel Cells

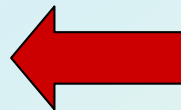
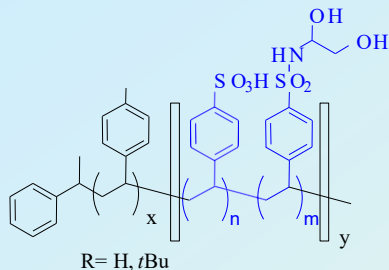

**DMFC Membranes  
MEAs**

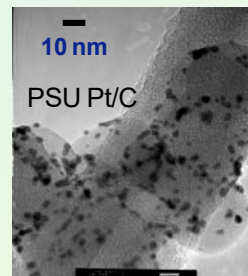

**DMFC Catalyst Discovery  
Optical catalyst screening**

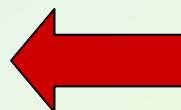
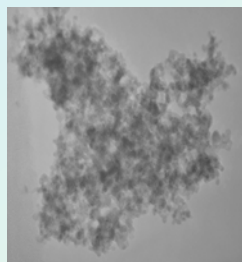

**DMFC Catalysts,  
Low Methanol Crossover Membranes**

**High throughput parallel  
Screening & testing**

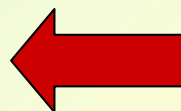
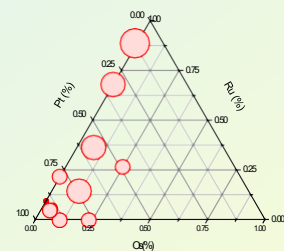
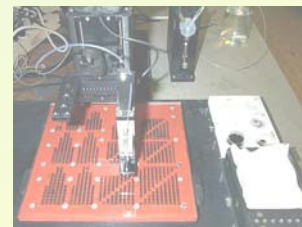
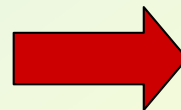

**DMFC anode catalyst preparation  
& characterization**



# DMFC System Design



## Objectives

- Design and optimize a miniature 1W DMFC system.
- Model scale-up to larger systems to determine overall system size, weight, and energy density.

## Challenges

- Integration and miniaturization of system components.
- Microfluidic design and processes required to maintain the structural and electrical integrity of the fuel cell system

## Accomplishments

- 1W & 2W DMFC Systems designed, built and tested.
- > 1000 hour operation demonstrated for 1W prototype

## Prototype 2W DMFC System



2W DMFC Charger

- Net power 2.5W, peak power 3.5W
- System Power Density 5W/L, 7.5W/Kg
- System Energy Density at 305Whr/L, 410Whr/Kg (w/1 week of fuel)
- BOP efficiency 75%
- Automated startup



# Basic Combat Hybrid Power System Architecture

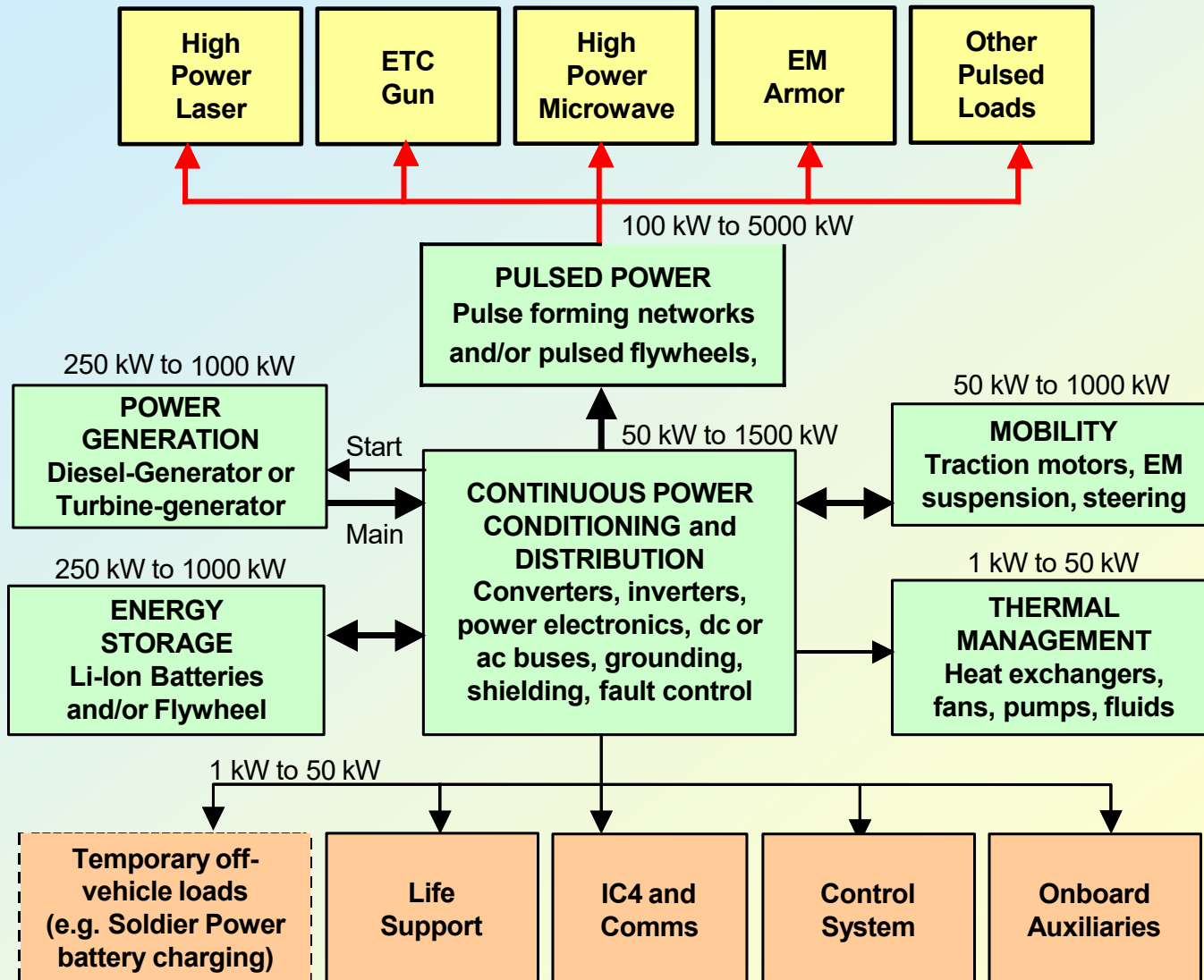



# Hybrid Electric Propulsion & Power



System Integration, Modeling & Analysis

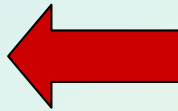
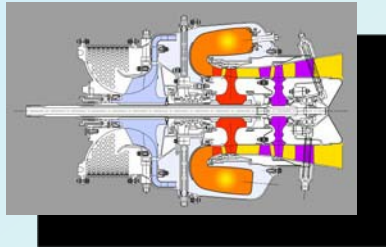
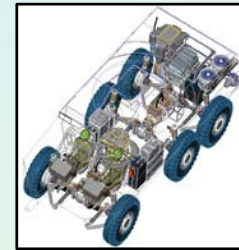
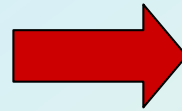

High Speed Ceramic Turbogenerator Robot Power Systems

Vehicle Integration, DC-DC Converters

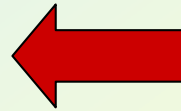
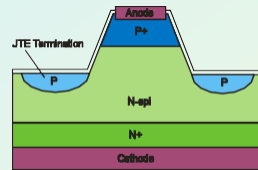
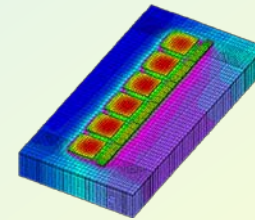
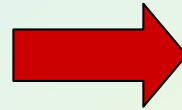

SiC Materials & Devices

Field Sustainment Power Conditioning

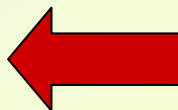
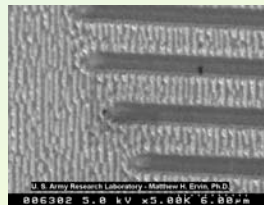
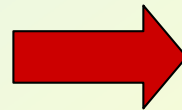

SiC Device Fab, Evaluation, Process Improvements, Converter Design, Turbogenerator Technology



# Hybrid Electric Propulsion & Power Vehicle Power Conversion



## Technical Challenges:

- Development and fabrication of high temperature and high power density power electronics to meet aggressive space requirements on combat Hybrid Electric Vehicles (HEV) for FCS program.
- Develop and test hybrid Si/SiC oil cooled 600 amp/1200 volt IGBT module and integrate into an oil cooled inverter.

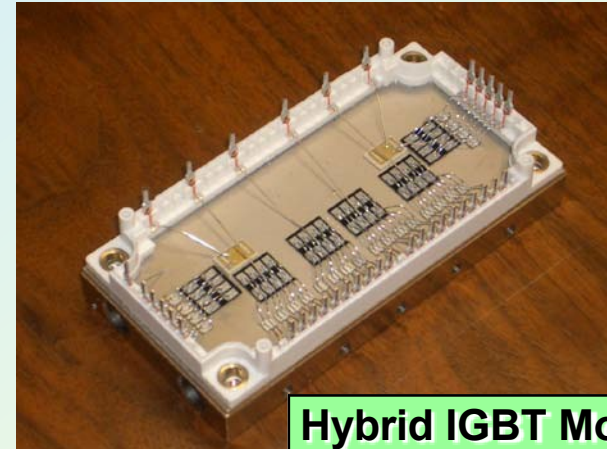

Hybrid IGBT Module

## Recent Accomplishments:

- Designed new driver card for inverter to support thermal and electrical testing.
- Completed detail chip layout drawing for hybrid module.
- Completed bench test fixture design to electrically and thermally test module.
- Successfully developed backside and front side metallization and soldering processes for soldering SiC SBD to cold plate.
- Successfully developed and tested soldering and wire bonding processes to be used on the module.
- Completed fabrication and assembly of 4 hybrid modules.

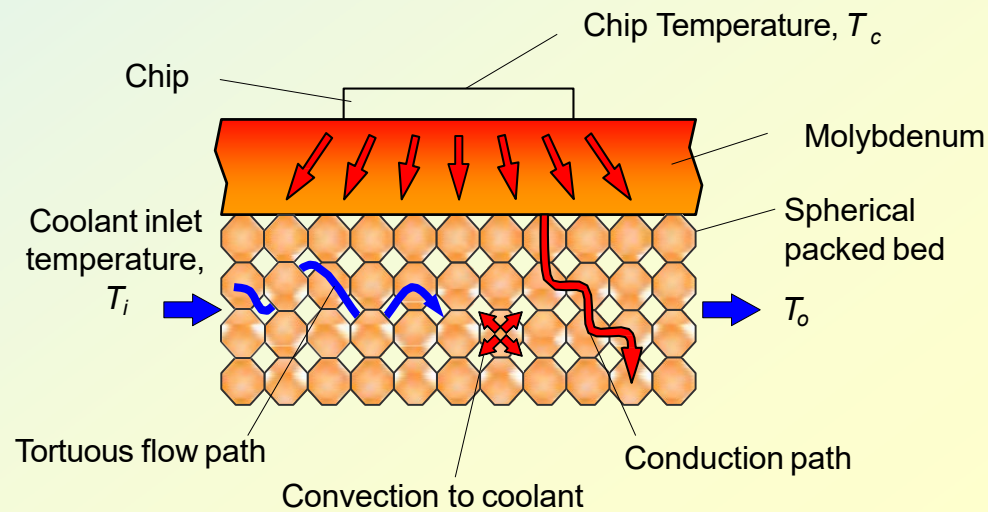

Transitioned to CHPS SIL for Evaluation in Prototype FCS Inverter



# Hybrid Electric Propulsion & Power High-Speed Ceramic Turbogenerator



## Program Objective

Develop and validate key technology enablers

## Technical Challenges:

- Compact & Fuel-efficient primary energy conversion subsystem
- High cycle temperatures
- Lubrication system limitations at high speeds
- Direct-coupled high-speed generators

## Recent Accomplishments:

- Initial screening experiments demonstrated that zirconia deposited on SiCN successfully prevents the development of silica at this interface during oxidation.
- Initiated integration of start function in the generator for the gearless/oilless FPT engine configuration.
- Assessment of electrical machinery for the hybrid electrical drive system has been completed. Research on and development of disk (axial gap) type PM machines for both generating and motoring is recommended

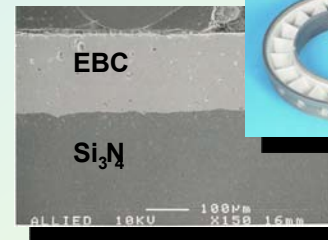

## Free Power Turbine

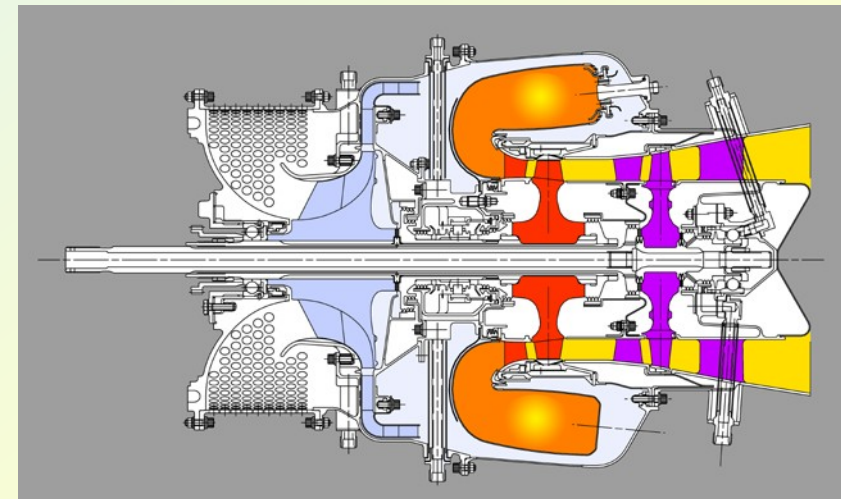

Specific Weight = 0.2 lb/hp  
Specific Volume = 0.04 ft<sup>3</sup>/hp





# Hybrid Electric Propulsion & Power Robot Power Systems



## Program Objective

Develop and demonstrate a power system that meets the mission requirements of a man-portable autonomous robot

## Technical Challenges:

- 'Small' Power System Unit up to 500W with peak and continuous power for mobility and payload
- Rechargeable and Expendable power pack versions
- Short-term solution with SOA battery technology, longer-term with fuel-cell or 'new' battery technology

## Recent Accomplishments:

- PacBot identified as demonstration platform.
- Power measurements on Talon and URBOT robots completed at SPAWAR. Voltage and current demands documented for conditions simulating vehicle mission components.
- Power System specification completed.

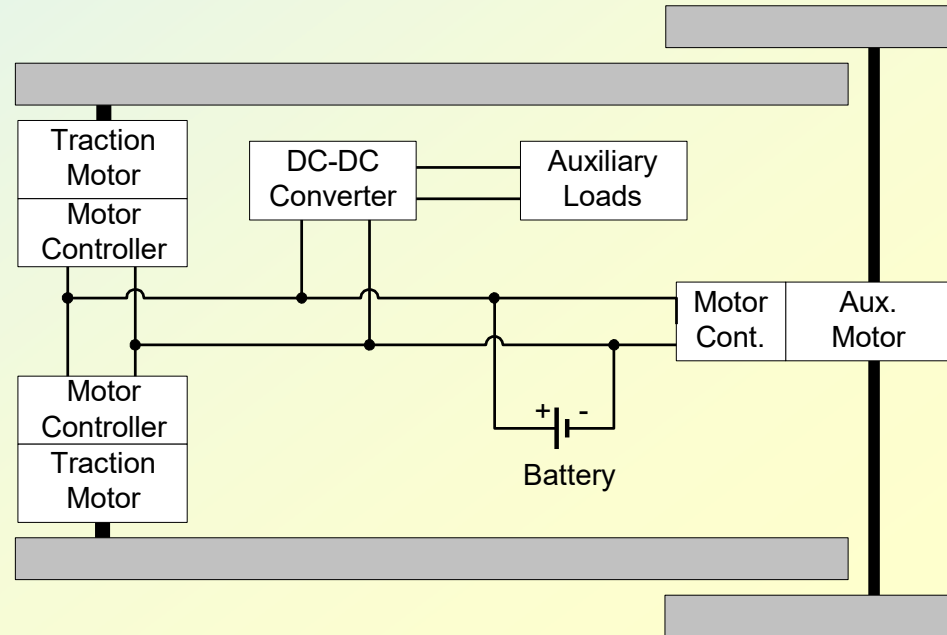
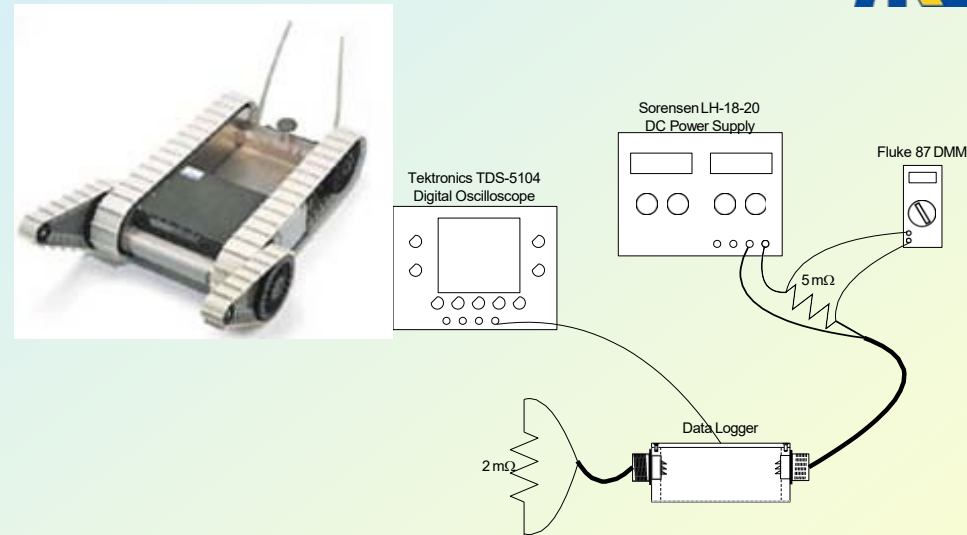

**Robot Power System Architecture**



# Summary

- P&E CTA is part of the DoD and other agency programs to find solutions and efforts will be made to collaborate with other programs as appropriate
- P&E CTA website for Government and Consortium access
- Electric power demands continue to increase

***Transformation for a Future Electric Force***